

ET KNIFE GATE VALVE

The ET model knife gate valve is a lug type valve designed according to MSS SP-81 and TAPPI TIS 405-8 for general industrial service applications. The design of the body and seat assures nonclogging shut off on suspended solids in industries such as Pulp & Paper, Power Plants, Mining, Chemical Plants, Wastewater Treatment Plants, Food & Beverage, etc

Product description:

- Uni-directional lug type knife gate valve
- Size range of DN50-900 (larger sizes upon request). See Dimension Charts for pressure rating
- Rising stem as standard. Non-rising stem also available
- Standard flange connection: DIN PN10 (EN 1092-2) and ANSI B16.5 (class 150)
Others available upon request
- Manual (handwheel, chainwheel, lever and bevel gear), pneumatic (single and double-acting), electric and hydraulic actuation options available
- Directives: 2006/42/EC (MACHINES), 2014/68/EU (PED) Fluid: Group 1(b), 2 (Cat. I. mod. A) and 2014/34/EU (ATEX)

Features:

- Lug type one piece cast stainless steel body with internal cast-in gate wedges and guides
- Port design as per the MSS SP-81 and TAPPI TIS 405-8 standards
- Stainless steel gate polished both sides to avoid jamming and seat damage
- Standard EPDM resilient seat. Metal-to-metal seat, as well as high performance rings and deflection cones available
- Long life PTFE impregnated synthetic fibre plus EPDM o-ring packing with easy access and adjustable gland follower. Wide range of packing materials available
- RAL-5015 blue epoxy-coating on all cast iron/carbon steel components
- Automated valves provided with gate guards in accordance with EU Safety Standards
- Other options: bonnets, V-ports, flush ports, special materials, fabricated valves, etc.
- Actuation accessories: limit & proximity switches, mechanical stops, positioners, solenoid valves, manual overrides, locking devices, fail safe systems, stem extensions and floor stands

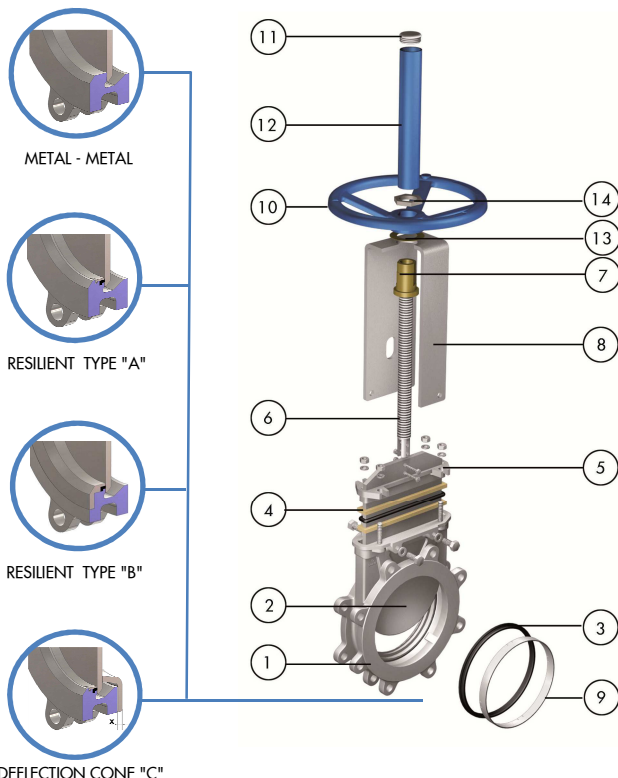
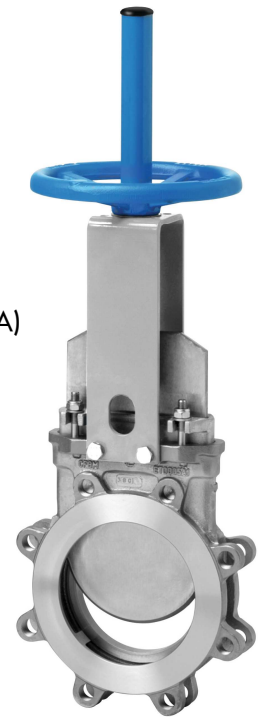

STANDARD PARTS LIST

Part	Stainless Steel:
1 Body	CF8M
2 Gate	AISI 316
3 Seat	Metal/Metal, EPDM
4 Packing	PTFE impreg. synth. fibre and EPDM o-ring
5 Gland Follower	CF8M
6 Stem	AISI 430
7 Stem Nut	Brass
8 Yoke	AISI 304 / Epoxy-coated carbon steel
9 Seat Retainer Ring	AISI 316
10 Handwheel	GJS400 (GGG40)
11 Cap	Plastic
12 Stem Protector	Epoxy-coated carbon steel
13 Friction Washer	Brass
14 Nut	Zinc-plated carbon steel

DIMENSIONS (mm) Handwheel Rising Stem

DN	Pressure	N	A	B	C	D	E	F	ØG	H	Weight (kg.)
50	10 bar	50	48	124	100	98	136	47	225	420	8
80	10 bar	80	51	149	100	119	162	47	225	470	10
100	10 bar	97	51	169	100	139	187	47	225	519	12,5
125	10 bar	117	57	169	100	150	223	47	225	613	16
150	10 bar	140	57	197	100	165	237	47	225	642	20
200	10 bar	184	70	247	122	203	309	67	310	820	32
250	10 bar	230	70	298	122	233	345	67	310	986	47
300	10 bar	275	76	349	122	273	390	69	410	1071	65
350	10 bar	305	76	391	193	312	433	66	410	1245	95
400	10 bar	351,6	89	439	193	347	478	66	410	1325	122
450	10 bar	390	89	483	197	415	552	67	550	1510	160
500	10 bar	435	114	542	197	450	611	67	550	1617	202
600	10 bar	522	114	637	197	501	697	67	550	1883	290

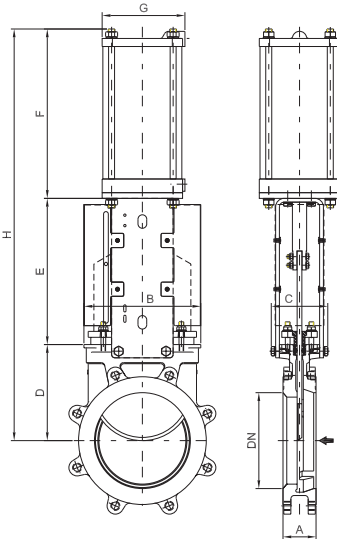
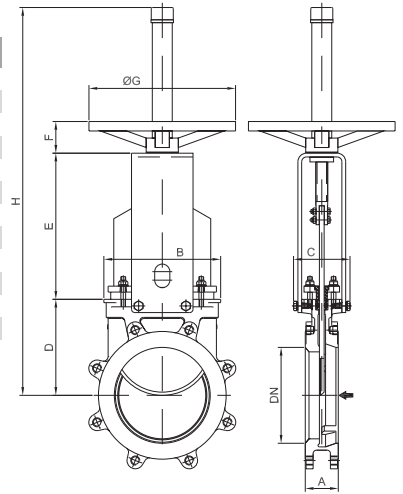

DIMENSIONS (mm) Pneumatic Actuator (D/A)

DN	Pressure	N	A	B	C	D	E	F	G	H	Weight (kg.)	Standard Cyl. Connect.
50	10 bar	50	48	124	100	98	136	178	115	412	10	C100/62 1/4"G
80	10 bar	80	51	149	100	119	162	211	115	492	12	C100/95 1/4"G
100	10 bar	97	51	169	100	139	187	231	115	557	15	C100/115 1/4"G
125	10 bar	117	57	169	100	150	223	271	140	644	21	C125/143 1/4"G
150	10 bar	140	57	197	100	165	237	296	140	698	27	C125/168 1/4"G
200	10 bar	184	70	247	122	203	309	358	175	870	46	C160/220 1/4"G
250	10 bar	230	70	298	122	233	345	428	220	1006	70	C200/270 3/8"G
300	10 bar	275	76	349	122	273	390	478	220	1141	89	C200/320 3/8"G
350	10 bar	305	76	391	193	312	459	549	277	1320	135	C250/375 3/8"G
400	10 bar	351,6	89	439	193	347	478	599	277	1424	162	C250/425 3/8"G
450	10 bar	390	89	483	197	415	552	680	382	1647	212	C300/475 1/2"G
500	10 bar	435	114	542	197	450	611	730	382	1791	290	C300/525 1/2"G
600	10 bar	522	114	637	197	501	697	830	382	2028	375	C300/625 1/2"G
750	7 bar	670	117	842	320	624	940	985	444	2549	645	C350/730 3/4"G
900	7 bar	810	117	970	320	775	1100	1202	515	3077	780	C400/930 3/4"G

DIMENSIONS (mm) Electric Actuator Rising Stem

DN	Pressure	N	A	B	C	D	E	F	ØG	H	I	J	L	M	Stem Ø X pitch	Torque (Nm)
50	10 bar	50	48	124	100	98	136	377	160	454	265	249	62	238	20x4	10
80	10 bar	80	51	149	100	119	162	424	160	501	265	249	62	238	20x4	10
100	10 bar	97	51	169	100	139	187	469	160	546	265	249	62	238	20x4	10
125	10 bar	117	57	169	100	150	223	516	160	593	265	249	62	238	20x4	15
150	10 bar	140	57	197	100	165	237	545	160	1122	265	249	62	238	20x4	20
200	10 bar	184	70	247	122	203	309	667	160	1255	265	249	62	238	24x5	30
250	10 bar	230	70	298	122	233	345	733	160	1321	265	249	62	238	24x5	45
300	10 bar	275	76	349	122	273	390	793	200	1381	283	254	65	248	24x5	70
350	10 bar	305	76	391	193	312	433	875	200	1463	283	254	65	248	36x6	110
400	10 bar	351,6	89	439	193	347	478	955	315	1543	389	336	91	286	36x6	160
450	10 bar	390	89	483	270	415	552	1142	315	1870	389	336	91	286	36x6	190
500	10 bar	435	114	542	270	450	611	1222	400	1950	389	339	91	286	36x6	270
600	10 bar	522	114	637	270	501	697	1444	400	2172	389	339	91	286	40x7	450
750	7 bar	670	117	842	320	624	883	1779	500	2832	430	365	117	303	50x8	550
900	7 bar	810	117	970	320	779	1046	2035	500	3080	430	365	117	303	60x9	850

